



VGCTS16 SHOWN ON STAND

## ROUND COUNTER TOP TILTING BRAISING PANS (16 GALLON)

**GAS AND ELECTRIC**

VGCTS16 ML-114827

VECTS16 ML-114825

### **- NOTICE -**

This Manual is prepared for the use of trained Vulcan Service Technicians and should not be used by those not properly qualified. If you have attended a Vulcan Service School for this product, you may be qualified to perform all the procedures described in this manual.

This manual is not intended to be all encompassing. If you have not attended a Vulcan Service School for this product, you should read, in its entirety, the repair procedure you wish to perform to determine if you have the necessary tools, instruments and skills required to perform the procedure. Procedures for which you do not have the necessary tools, instruments and skills should be performed by a trained Vulcan Service Technician.

Reproduction or other use of this Manual, without the express written consent of Vulcan, is prohibited.

# TABLE OF CONTENTS

GENERAL .....	3
Introduction .....	3
Model Designations .....	3
Control Location .....	3
Specifications .....	4
Electric Braising Pan .....	4
Gas Braising Pan .....	4
Tools .....	4
REMOVAL AND REPLACEMENT OF PARTS .....	5
Illustration - Electric Model .....	5
Illustration - Gas Model .....	6
Thermostats (Electric Model) .....	7
Right and Left Console Cover .....	8
Bottom Cover .....	8
Temperature Controller and Potentiometer (Gas Model) .....	8
Hi Limit Thermostat (Gas Model) .....	8
Heater Contactors .....	9
Heating Elements .....	9
Pan Assembly .....	10
Bearings .....	11
Limit Switch (Gas Model) .....	11
SERVICE PROCEDURES AND ADJUSTMENTS .....	12
Manifold Pressure Adjustment (Gas Model) .....	12
Flame Sense Probe (Gas Model) .....	13
Hot Surface Ignitor (Gas Model) .....	14
Temperature Controller And Potentiometer Test (Gas Model) .....	14
Heating Elements (Electric Model) .....	15
ELECTRICAL OPERATION .....	16
Component Function .....	16
Sequence of Operation .....	16
Electric Model .....	16
Gas Model .....	17
Schematic Diagrams .....	18
Electric Model .....	18
Gas Model .....	19
Wiring Diagrams .....	20
Electric Model (208/240V) .....	20
Electric Model (480V) .....	21
Gas Model .....	22
TROUBLESHOOTING .....	23
All Models .....	23
Gas Models Only .....	24

# GENERAL

## INTRODUCTION

The Vulcan round tilting braising pan (skillet) is a versatile piece of cooking equipment. It can be used to stew, simmer, sear, pan fry, grill or saute food products under an evenly distributed heating surface. Once the product is fully cooked, the pan can be tilted using the handle to empty the product from the pan. The full capacity of the pan is 16 gallons (60.6 liters) and can be mounted on a counter top or optional stand.

### Model Designations

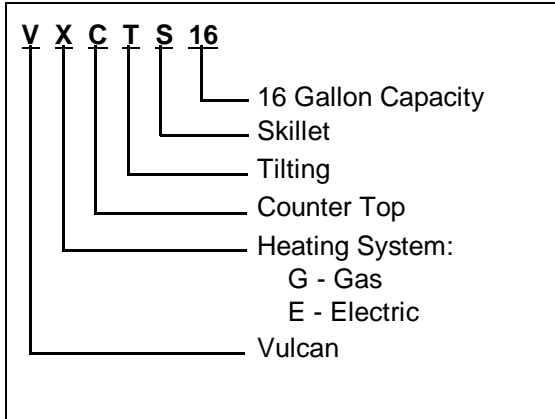

### Control Location

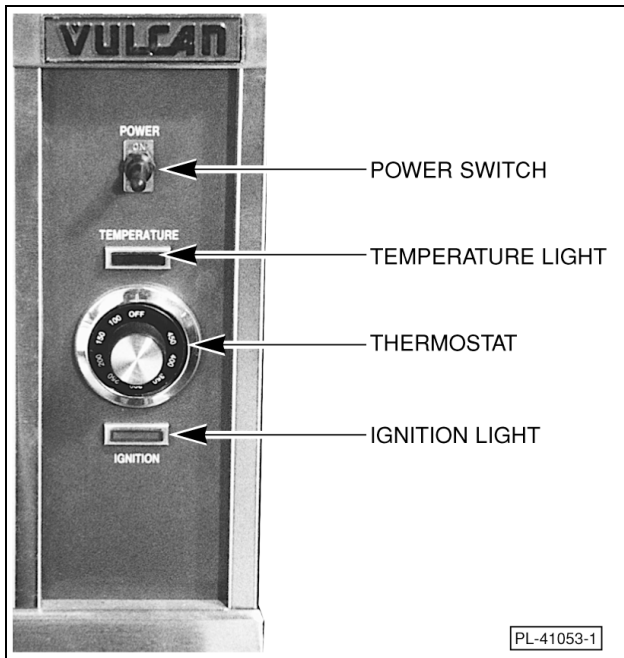

Gas Model Shown

**SPECIFICATIONS**

**Electric Braising Pan**

MODEL	TOTAL KW	AMPERAGE				
		1 PHASE		3 PHASE		
		208V	240V	208V	240V	480V
VECTS16	7.5	36	31.3	20.8	18.1	9.0

**Gas Braising Pan**

MODEL	INPUT BTU/HR		MANIFOLD PRESSURE (INCHES W.C.)		LINE PRESSURE (INCHES W.C.)					LOAD (WATTS)	AMPS (MAX)
	NAT.	PROP.	NAT.	PROP.	NATURAL		PROPANE				120V 60HZ
					RECOMMEND	MIN	RECOMMEND	MIN	MAX		
VGCTS16	30,000	30,000	3.5	10.0	7.0	5.0	11.0	11.0	14.0	180	1.5

**TOOLS**

**Standard**

- Standard set of hand tools.
- VOM with an AC current tester (meter sensitivity should be at least 20,000 ohms per volt can be used).
- Gas leak checking equipment.
- Manometer
- Temperature meter (thermocouple type)

# REMOVAL AND REPLACEMENT OF PARTS

Refer to the appropriate illustration for component location and identity. Only major components are covered by a replacement procedure.

## ILLUSTRATION - ELECTRIC MODEL

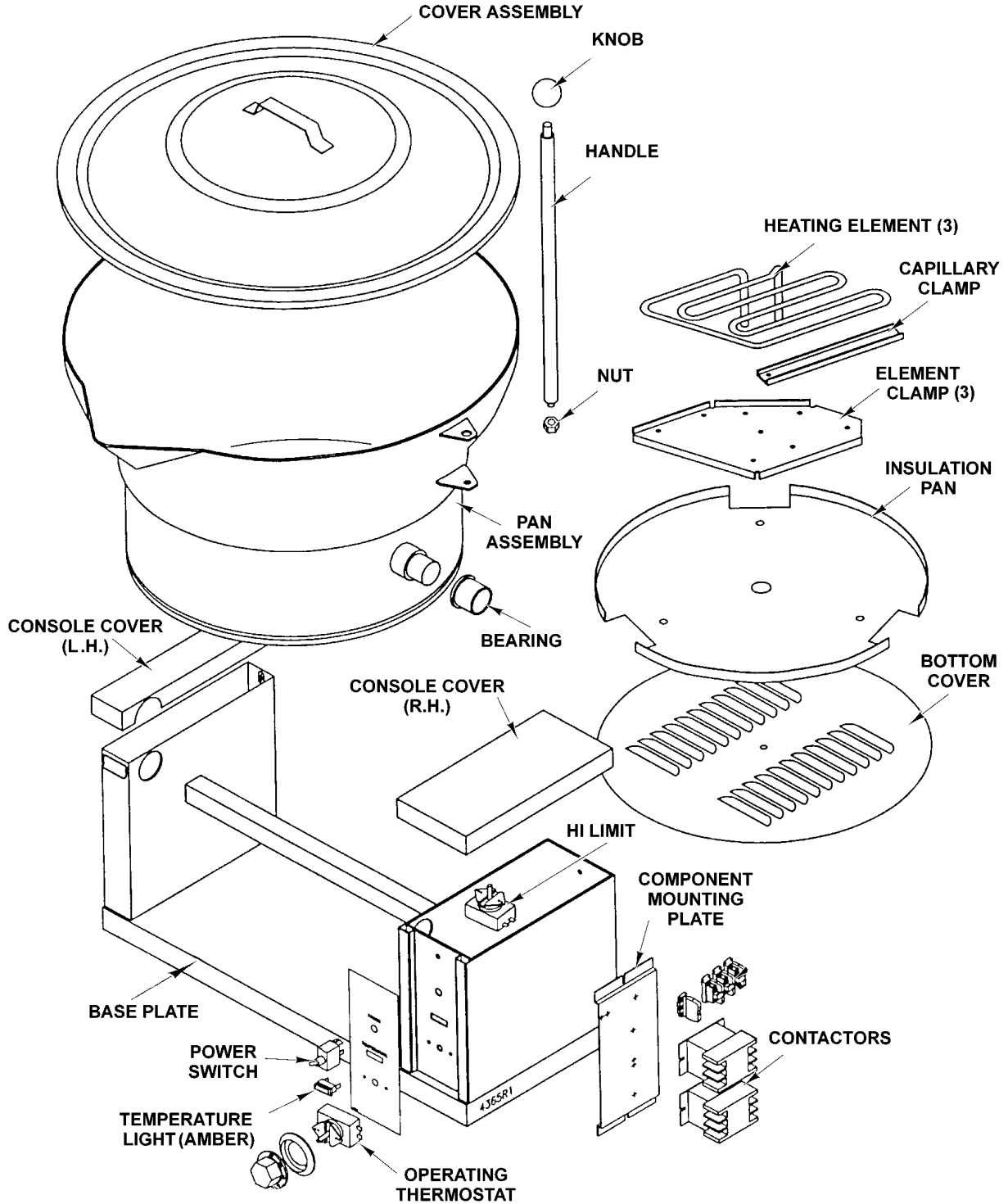

DERIVED FROM PL-52816

3980

ILLUSTRATION - GAS MODEL

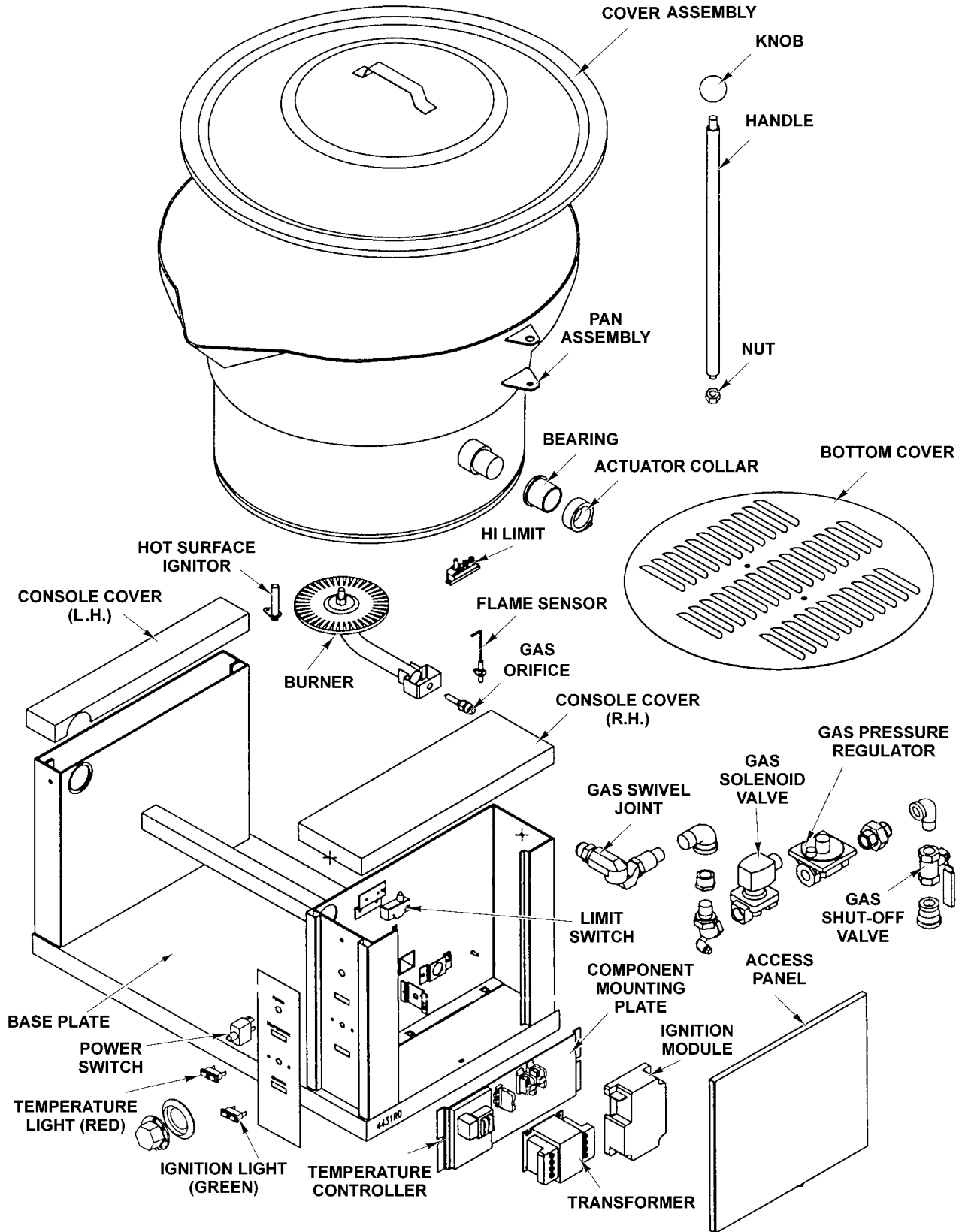

DERIVED FROM PL-52815

3981

## THERMOSTATS (Electric Model)

**WARNING:** DISCONNECT THE ELECTRICAL POWER TO THE MACHINE AT THE MAIN CIRCUIT BOX. PLACE A TAG ON THE CIRCUIT BOX INDICATING THE CIRCUIT IS BEING SERVICED.

1. Remove right console cover as outlined under "RIGHT AND LEFT CONSOLE COVER".
  - A. If replacing operating thermostat proceed to step 2.
  - B. If replacing Hi Limit thermostat proceed to step 4.
2. Remove component mounting plate to gain access to the operating thermostat by removing nut from threaded stud.

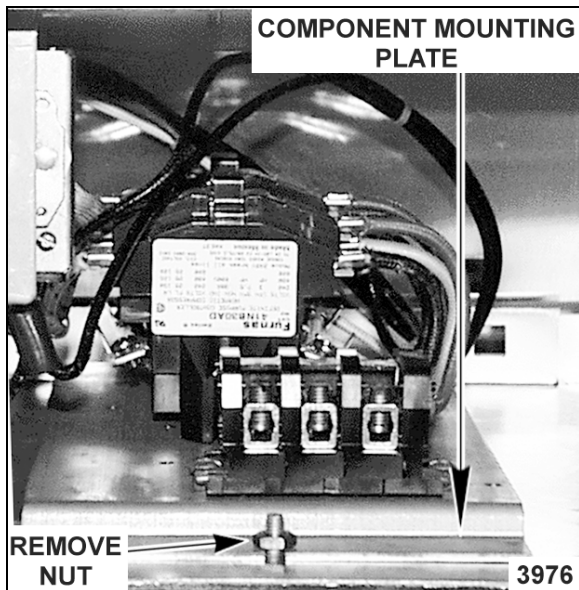

- A. Grasp plate and pull upwards while rotating left to right to free it from bottom fastener.
3. Pull thermostat knob off from the control panel and remove mounting screws and bezel ring.
  - A. Lift thermostat out of control box.
  - B. Remove lead wires from terminals.
4. Remove thermostat bulb from the bottom of the pan for the thermostat being replaced.
  - A. Remove bottom cover as outlined under "BOTTOM COVER".

- B. Disconnect heater lead wires and mark accordingly for proper replacement.

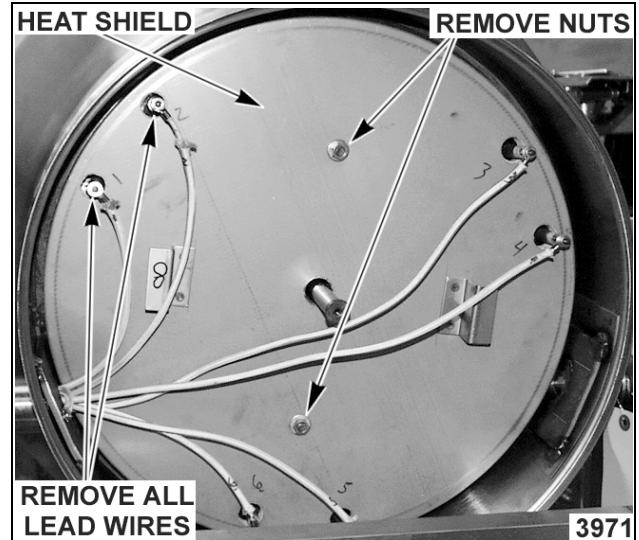

- C. Remove the two nuts from mounting stud that secure the insulation pan to the bottom of the braising pan.
- D. Pull the heater lead wires back through the opening in bearing to allow clearance for the insulation pan to be lifted out.
- E. Remove the nuts from the capillary clamp that secure both thermostat bulbs to the bottom of the braising pan.

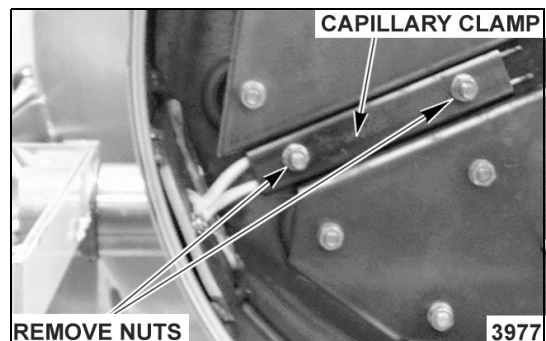

- F. Pull the capillary tube and bulb for the thermostat being replaced, back through the opening in bearing and remove from unit.
5. Reverse procedure to install a new thermostat and check for proper operation.

## RIGHT AND LEFT CONSOLE COVER

**WARNING:** DISCONNECT THE ELECTRICAL POWER TO THE MACHINE AT THE MAIN CIRCUIT BOX. PLACE A TAG ON THE CIRCUIT BOX INDICATING THE CIRCUIT IS BEING SERVICED.

1. Remove screw at the rear of the cover.
2. Lift up on cover while working it back and forth to free it at the front.
3. Reverse procedure to install.

## BOTTOM COVER

**WARNING:** DISCONNECT THE ELECTRICAL POWER TO THE MACHINE AT THE MAIN CIRCUIT BOX. PLACE A TAG ON THE CIRCUIT BOX INDICATING THE CIRCUIT IS BEING SERVICED.

1. Tilt braising pan forward until it comes to rest on the stop bar.
2. Remove screw(s) holding the round cover.
3. Reverse procedure to install.

## TEMPERATURE CONTROLLER AND POTENTIOMETER (GAS MODEL)

**WARNING:** DISCONNECT THE ELECTRICAL POWER TO THE MACHINE AT THE MAIN CIRCUIT BOX. PLACE A TAG ON THE CIRCUIT BOX INDICATING THE CIRCUIT IS BEING SERVICED.

**WARNING:** SHUT OFF THE GAS SUPPLY BEFORE SERVICING THE UNIT.

1. Remove right console cover as outlined under "RIGHT AND LEFT CONSOLE COVER".
2. Pull out the right side access panel to expose the compartment controls.
3. Loosen the two set screws from the temperature dial and pull the dial off.
4. Remove the bezel ring and potentiometer mounting screws.
5. Remove the nut securing the potentiometer to the mounting bracket.

6. Disconnect the lead wires from the temperature controller board.
7. Remove the mounting screws.
8. Reverse procedure to install a new temperature controller and check for proper operation.

## HI LIMIT THERMOSTAT (Gas Model)

**WARNING:** DISCONNECT THE ELECTRICAL POWER TO THE MACHINE AT THE MAIN CIRCUIT BOX. PLACE A TAG ON THE CIRCUIT BOX INDICATING THE CIRCUIT IS BEING SERVICED.

**WARNING:** SHUT OFF THE GAS SUPPLY BEFORE SERVICING THE UNIT.

1. Remove the bottom cover as outlined under "BOTTOM COVER".
2. Remove the screws securing the heat shield box to the underside of the pan and lift off.

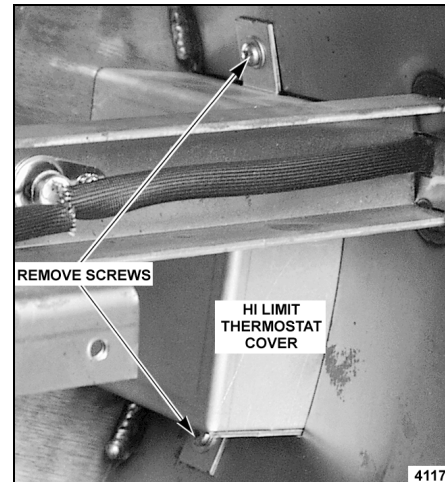

3. Disconnect the lead wires from the high limit.

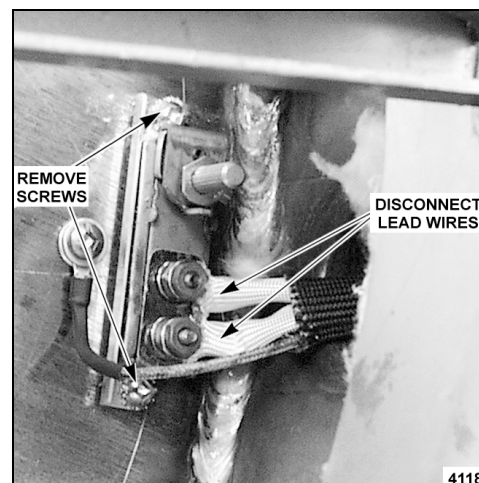



4. Remove the screws securing the high limit to the underside of the pan.
5. Reverse procedure to install a new hi limit and check unit for proper operation.

## HEATER CONTACTORS

**WARNING:** DISCONNECT THE ELECTRICAL POWER TO THE MACHINE AT THE MAIN CIRCUIT BOX. PLACE A TAG ON THE CIRCUIT BOX INDICATING THE CIRCUIT IS BEING SERVICED.

1. Remove right console cover as outlined under "RIGHT AND LEFT CONSOLE COVER".
2. Remove component mounting plate to gain access to contactors by removing nut from threaded stud.

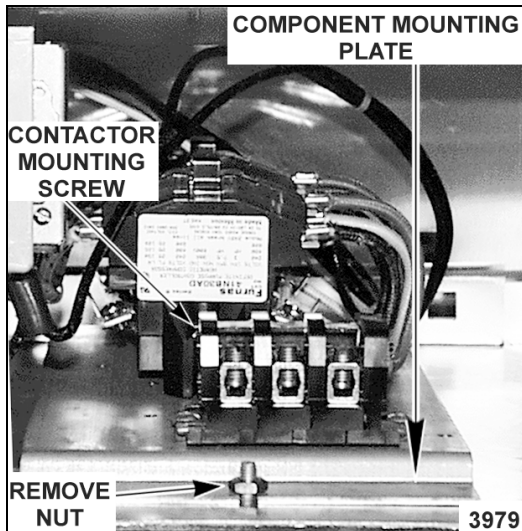

A. Grasp plate and pull upwards while rotating left to right to free it from bottom fastener.

3. Remove lead wires from contactor being replaced.
4. Remove contactor mounting screws.
5. Reverse procedure to install a new contactor and check for proper operation.

## HEATING ELEMENTS

**WARNING:** DISCONNECT THE ELECTRICAL POWER TO THE MACHINE AT THE MAIN CIRCUIT BOX. PLACE A TAG ON THE CIRCUIT BOX INDICATING THE CIRCUIT IS BEING SERVICED.

1. Remove bottom cover as outlined under "BOTTOM COVER".
2. Disconnect heater lead wires and mark accordingly for proper replacement.

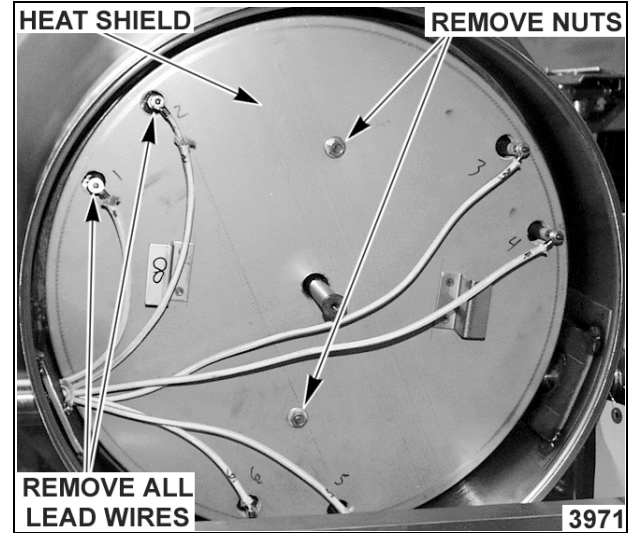

3. Remove the two nuts from mounting stud that secure the insulation pan to the bottom of the braising pan.
4. Push the heater lead wires back through the opening in bearing to allow clearance for the insulation pan to be lifted out.
5. Remove the nuts securing the element clamp to the braising pan bottom for the element being replaced.

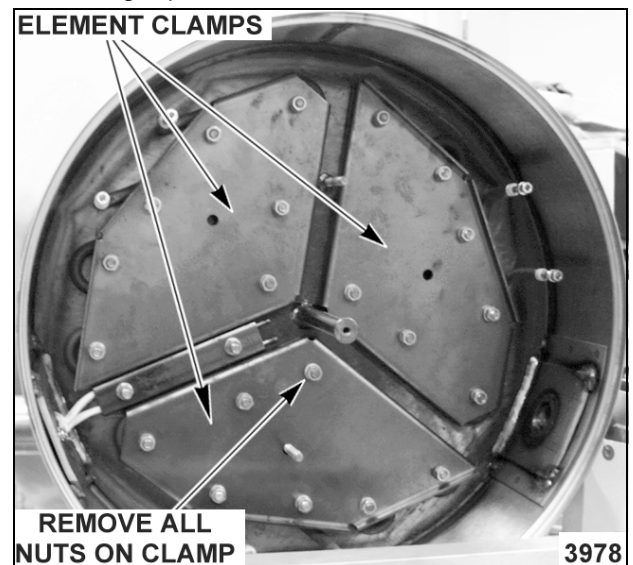

6. Replace with a new element and reverse procedure to install.

**PAN ASSEMBLY**

**WARNING:** DISCONNECT THE ELECTRICAL POWER TO THE MACHINE AT THE MAIN CIRCUIT BOX. PLACE A TAG ON THE CIRCUIT BOX INDICATING THE CIRCUIT IS BEING SERVICED.

1. Remove right and left console cover as outlined under "RIGHT AND LEFT CONSOLE COVER".
2. Remove bottom cover as outlined under "BOTTOM COVER".
3. Electric model only - for gas model proceed to step 4.
  - A. Remove the heater lead wires and heating elements as outlined under "HEATING ELEMENTS".
  - B. Proceed to step 5.
4. Gas model only.

**WARNING:** SHUT OFF THE GAS SUPPLY BEFORE SERVICING THE UNIT.

**WARNING:** ALL GAS JOINTS DISTURBED DURING SERVICING MUST BE CHECKED FOR LEAKS. CHECK WITH A SOAP AND WATER SOLUTION (BUBBLES). DO NOT USE AN OPEN FLAME.

- A. Disconnect the component lead wires for the HSI, FSP, HL AND TC from the terminal strip located in the left hand console and pull the insulation sleeve and wires through opening in bearing.

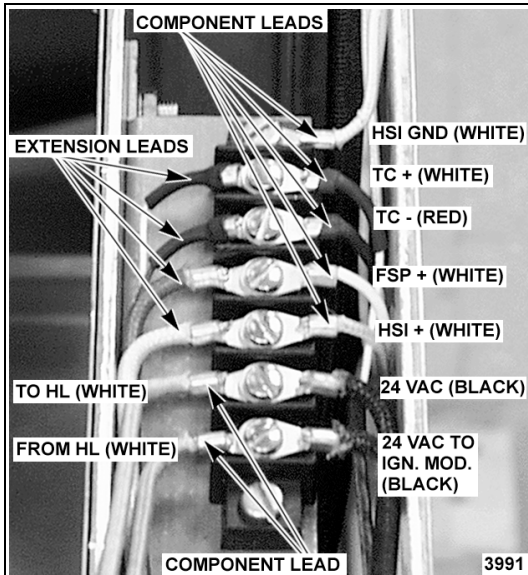

- B. Remove those same components from the underside of pan and set them aside for re-installing on replacement pan assembly.

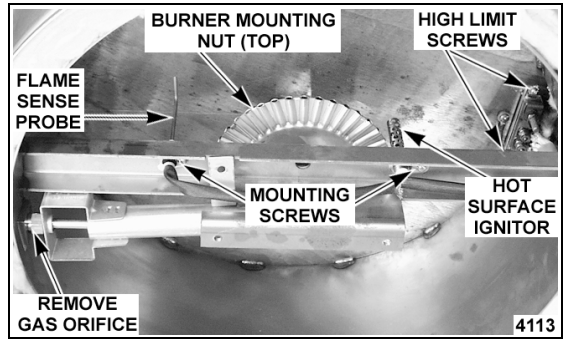

- C. Loosen the nut at the top of the burner that secures the burner to bracket and remove.
- D. Unscrew the gas orifice and remove.
- E. Separate the brass union just below the gas swivel connector and unscrew the threaded end of the connector from the pan sleeve.
- F. Loosen the set screw at the top of the actuator collar and remove the collar.

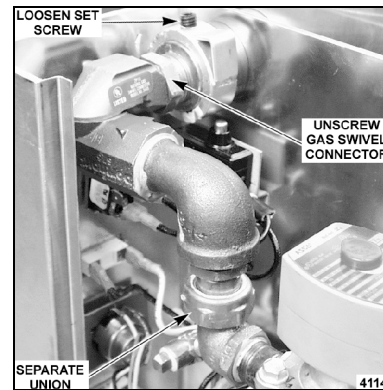

- G. Disconnect the incoming gas supply line. Remove the gas line assembly by separating the second union in the gas assembly line and removing the nuts securing the mounting bracket.

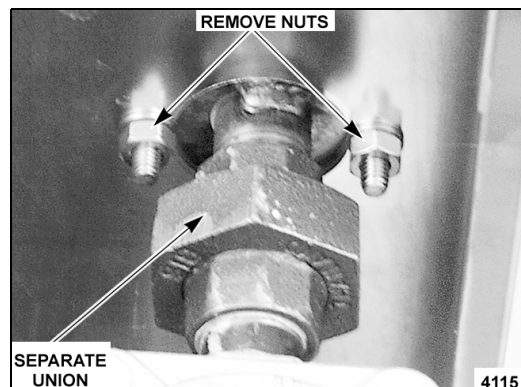

5. Unbolt the braising pan from the mounting surface or stand.
6. Lay the braising pan on its back to expose the four base plate mounting nuts and bolts.
7. Remove the nuts and carriage bolts on the right side to separate the base plate from the right side support member.



8. Gently strike the inner side of the support member by hand or rubber mallet to dislodge the pan assembly sleeve from the bearing. Before the sleeve separates from the bearing, grasp the pan for support.

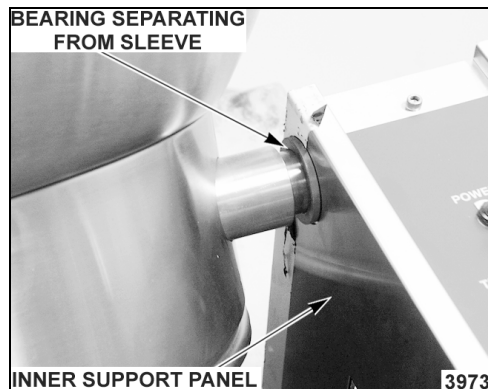

9. Grasp the pan firmly and then pull it away from the left side bearing.

**NOTE:** CHECK CONDITION OF BOTH BEARINGS WHILE PAN IS OUT AND REPLACE IF NECESSARY.

10. Replace with a new pan and reverse procedure to install.

## BEARINGS

**WARNING:** DISCONNECT THE ELECTRICAL POWER TO THE MACHINE AT THE MAIN CIRCUIT BOX. PLACE A TAG ON THE CIRCUIT BOX INDICATING THE CIRCUIT IS BEING SERVICED.

1. Remove the pan assembly as outlined under "PAN ASSEMBLY".
2. Remove the bearing to be replaced from the support member.

**NOTE:** CHECK CONDITION OF BEARING ON OPPOSITE SIDE AND REPLACE IF NECESSARY.

3. Replace with a new bearing and reverse procedure to install.

## LIMIT SWITCH (Gas Model)

**WARNING:** DISCONNECT THE ELECTRICAL POWER TO THE MACHINE AT THE MAIN CIRCUIT BOX. PLACE A TAG ON THE CIRCUIT BOX INDICATING THE CIRCUIT IS BEING SERVICED.

1. Remove right console cover as outlined under "RIGHT AND LEFT CONSOLE COVER".
2. Pull out the right side access panel to expose the compartment controls.
3. Disconnect the lead wires from the switch.
4. Tilt braising pan forward until it comes to rest on the stop bar.
5. Remove the screws securing the switch to the bracket.
6. Reverse procedure to install and check for proper operation.

# SERVICE PROCEDURES AND ADJUSTMENTS

**WARNING:** CERTAIN PROCEDURES IN THIS SECTION REQUIRE ELECTRICAL TEST OR MEASUREMENTS WHILE POWER IS APPLIED TO THE MACHINE. EXERCISE EXTREME CAUTION AT ALL TIMES. IF TEST POINTS ARE NOT EASILY ACCESSIBLE, DISCONNECT POWER, ATTACH TEST EQUIPMENT AND REAPPLY POWER TO TEST.

## MANIFOLD PRESSURE ADJUSTMENT (Gas Model)

**WARNING:** DISCONNECT THE ELECTRICAL POWER TO THE MACHINE AT THE MAIN CIRCUIT BOX. PLACE A TAG ON THE CIRCUIT BOX INDICATING THE CIRCUIT IS BEING SERVICED.

**WARNING:** SHUT OFF THE GAS SUPPLY BEFORE SERVICING THE UNIT.

1. Remove the right side console cover as outlined under "RIGHT AND LEFT CONSOLE COVER".
2. Pull out the right side access panel to expose the compartment controls.
3. Remove the 1/4" NPT pipe plug from the manifold and attach a manometer.
4. Remove the adjustment screw cap to access the pressure adjustment screw.

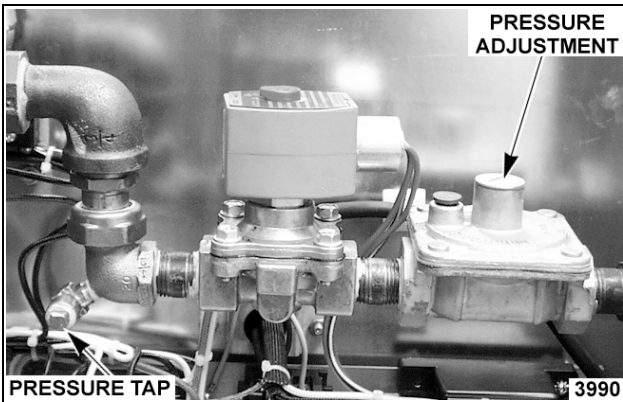

5. Plug in the unit, turn "on" the gas, set the power switch to "on" and set the thermostat.

**NOTE:** Accurate gas pressure adjustments can only be made with the gas "ON" and the burner lit.

6. After the burner lights, set the pressure as outline below:
  - A. To increase pressure, turn the screw clockwise.
  - B. To decrease pressure, turn the screw counterclockwise.

PRESSURE READINGS (INCHES W.C.)				
GAS TYPE	MANIFOLD	LINE		
		RECOMMENDED	MIN	MAX
NATURAL	3.5	7.0	5.0	14
PROPANE	10.0	11.0	11.0	

\* If the incoming line pressure is **less than** the minimum stated, then the manifold pressure can not be set correctly.

7. Once the correct pressure has been set, turn the power switch "OFF", replace the adjustment screw cap and manifold pipe plug.
8. Check unit for proper operation.

## FLAME SENSE PROBE (Gas Model)

**WARNING:** THE FOLLOWING STEPS REQUIRE POWER TO BE APPLIED TO THE UNIT DURING THE TEST. USE EXTREME CAUTION AT ALL TIMES.

1. Assure proper ground, correct polarity and that the value of incoming voltage is correct.
  - A. Check the flame sense probe micro amp current by disconnecting the flame sense probe lead from the terminal strip and placing a V-O-M in series.

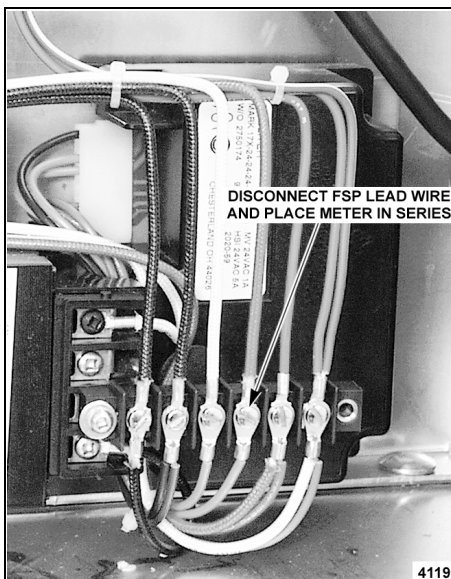

- B. Switch the meter leads to measure current and set the meter to read micro amps DC.
- C. Open the gas valve, turn power switch ON and set thermostat.
- D. Observe meter reading.
  - 1) If the reading is greater than 0.5 micro amps DC then the problem is not with the FSP. Replace ignition control module and check for proper operation.

- 2) If the reading is less than 0.5 micro amps, turn thermostat and power switch OFF. Check the flame sense probe for corrosion or grease build up and for loose or dirty connections on the terminal strips under the right and left console covers. If FSP is dirty, clean with sandpaper and repeat step 1C. Also, Check the flame sense probe position as outlined below in step two. Lastly, visually inspect the burner flame. If flame appears low or not burning correctly, then check the gas manifold pressure as outlined under "MANIFOLD PRESSURE ADJUSTMENT (GAS MODELS)". If pressure is not set correctly then adjust and check for proper operation.

2. Perform a visual check to determine if the flame sense probe is in the upper portion of flame. If the probe is bent or not in the upper portion of the flame then check alignment and adjust as necessary.
  - A. The center line of the probe should be approximately  $2 \frac{9}{16}$  inches from the underside of the pan and 4 inches up from the center line of the burner.

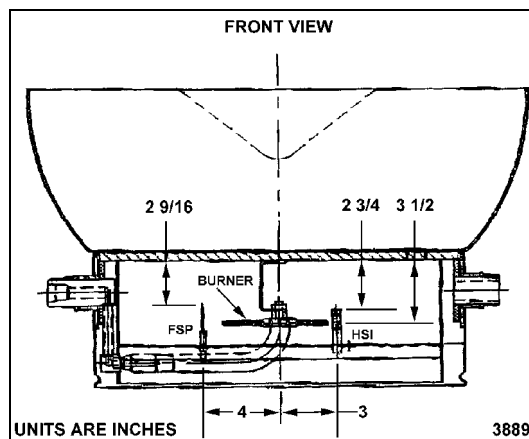

- B. If no adjustments can be made to the probe to correct its alignment then replace and check unit for proper operation.

## HOT SURFACE IGNITOR (GAS MODEL)

1. Check to see if hot surface ignitor is operating during **ignition trial** by:
  - A. Visual verification - HSI should be heating up "glowing brightly" to ignite gas.
  - B. Voltage verification - check for 24VAC to HSI termination on the edge connector to ground.

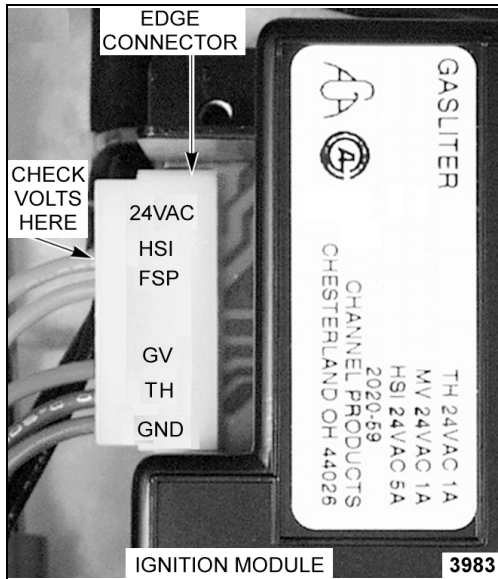

**WARNING:** DISCONNECT THE ELECTRICAL POWER TO THE MACHINE AT THE MAIN CIRCUIT BOX. PLACE A TAG ON THE CIRCUIT BOX INDICATING THE CIRCUIT IS BEING SERVICED.

2. Unplug the edge connector from the ignition module and check resistance between HSI lead wire and ground.

HSI CONDITION	RESISTANCE (approx. Ohms)
COLD	1 - 4
HOT	8 - 10

## TEMPERATURE CONTROLLER AND POTENTIOMETER TEST (GAS MODEL)

**WARNING:** THE FOLLOWING STEPS REQUIRE POWER TO BE APPLIED TO THE UNIT DURING THE TEST. USE EXTREME CAUTION AT ALL TIMES.

### Temperature Controller

1. Assure a proper ground, correct polarity and that the value of incoming voltage is correct.
2. Turn the gas supply on, power switch ON and set the thermostat to call for heat. The braising pan must also be down to close limit switch.
3. Verify the temperature controller is receiving power (120VAC) across L1 & L2. Once the relay contacts close, the temperature light on the front control panel will illuminate and the step down transformer receives power.
  - A. If controller output remains for approximately 20 seconds then drops off, an open thermocouple condition may exist. Replace the thermocouple and check for proper operation.
  - B. If the controller remains energized but burner does not come on, verify the relay contacts (N.O.) are opening and closing when power to the controller is removed and applied. Check voltage out between N.O. and L2.
    - 1) If relay is functioning properly then the problem is not with the controller. See Troubleshooting section.
    - 2) If relay is not functioning properly then replace controller and check proper operation.

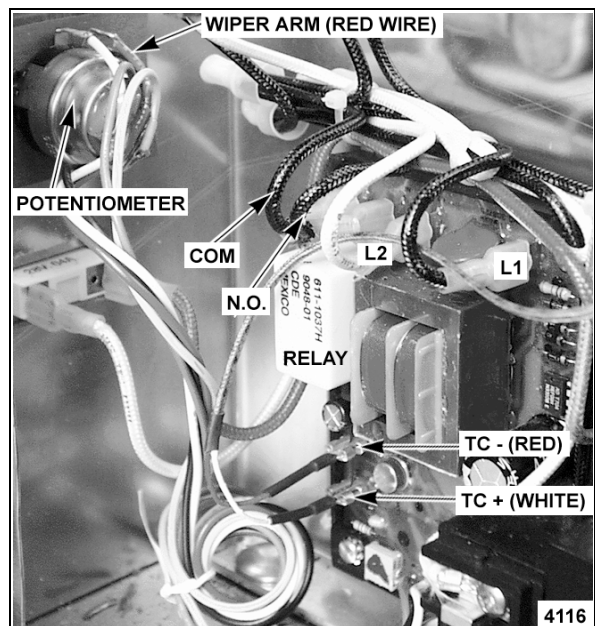

**Potentiometer**

Perform the following test procedure to verify the potentiometer is functioning properly and to confirm the temperature setting of the dial. A V-O-M connected from TC (-) to the wiper (red) on the potentiometer will read a voltage that corresponds to the set point temperature. Ex. If the set point is 300°F the DC voltage measured at the wiper should be approximately 1.49 volts.

1. If the thermocouple condition has not been verified as described in step 3A above, place a jumper across TC (-) and TC (+). If the thermocouple condition has been verified, proceed to step 2.

**NOTE:** Remove jumper when test is completed.

2. Connect the black meter lead of a V-O-M to the TC (-) on the temperature controller.
3. Connect the red meter lead of a V-O-M to the red wire (wiper arm) on the potentiometer.
4. Turn the power switch on and set the temperature dial to 100°F. Increase set point to 200°F, 300°F, 400°F and 450 °F while monitoring the voltage change between dial set points. Compare the meter readings to the chart below.

TEMPERATURE SETTING (°F)	APPROXIMATE DC VOLTAGE
100	0.38
200	0.93
300	1.49
400	2.0
450	2.3

- A. If the voltage measurements agree with those listed in the table and the increase in voltage was smooth without drops or spikes then the potentiometer is functioning properly.
- B. If the voltage measurements do not agree with those listed in the table or the increase in voltage was not smooth but with drops or spikes then the potentiometer is not functioning properly. Replace the temperature controller and potentiometer assembly and check unit for proper operation.

**HEATING ELEMENTS  
(ELECTRIC MODEL)**

**WARNING:** THE FOLLOWING STEPS REQUIRE POWER TO BE APPLIED TO THE UNIT DURING THE TEST. USE EXTREME CAUTION AT ALL TIMES.

1. Measure the voltage at the heating element terminals and verify it against the data plate voltage.
  - A. If voltage is incorrect, find the source of the problem.
2. If voltage is correct, check current draw (amps) through the heating element lead wires. If current draw is correct then heating element is ok. **See table below for proper values.**
  - A. If current draw is not correct then, replace heating element.
3. Check for proper operation.

VOLTAGE	TOTAL KW	AMPERAGE PER LINE		OHMS PER ELEMENT
		1 PH	3 PH	
208	7.5	36.1	20.9	17.4
240	7.5	31.3	18.1	23.1
480	7.5		9.0	30.6

**NOTE:** Values in the table are nominal. Tolerance is +5/-10 %.

# ELECTRICAL OPERATION

## COMPONENT FUNCTION

<b>Heater Contactors</b> . . . . .	Controls power to heating elements. (electric models only)
<b>Heating Elements (3)</b> . . . . .	Heat the braising pan cooking surface. (electric models only)
<b>Transformer</b> . . . . .	Provides 24VAC power to ignition control module and HSI. (gas models only)
<b>Ignition Module</b> . . . . .	Controls and monitors gas heating. Applies power to HSI for burner ignition, monitors flame presence through FSP, controls 5 second purge time and 8.5 second ignition trial time and powers gas solenoid valve. (gas models only)
<b>Temperature Light</b> . . . . .	Indicates the power switch is on and a temperature setting dialed. Light goes out when set point temperature is reached and will come back on when temperature drops below set point.
<b>Ignition Light</b> . . . . .	Indicates gas burner is on. (gas models only)
<b>FSP (Flame Sense Probe)</b> . . . . .	Supplies a current signal back to the ignition module indicating the presence of a flame. (gas models only)
<b>HSI (Hot Surface Igniter)</b> . . . . .	When Ignition module applies power, the HSI element heats up to very high temperatures to ignite the gas. (gas models only)
<b>Power Switch</b> . . . . .	Controls electrical power to the control circuit.
<b>Limit Switch</b> . . . . .	Removes electrical power to the temperature control board when the pan is tilted. (gas models only)
<b>Gas Solenoid Valve</b> . . . . .	Allows gas flow to burner when solenoid is energized. A normally closed valve. (gas models only)
<b>High Limit Thermostat</b> . . . . .	Will not allow heater contactor (on electric models) or ignition module (on gas models) to energize if the pan surface temperature goes beyond 536°F (280°C).
<b>Control Thermostat</b> . . . . .	Cycles power to heater contactors to maintain the set point temperature. (electric models only)
<b>Temperature Controller</b> . . . . .	Cycles power to the ignition control module to maintain the set point temperature. (gas models only)

## SEQUENCE OF OPERATION

### Electric Model

1. Conditions.
  - A. Braising Pan connected to correct voltage and is properly grounded.
  - B. Power switch OFF.
  - C. High limit thermostat contacts closed.
  - D. Control Thermostat dial OFF.
  - E. Temperature light OFF.
2. Power switch turned ON.
  - A. L1 voltage supplied through high limit thermostat contacts (N.C.) to one side of the control thermostat.
  - B. L3 voltage to one side of contactor coils.
3. Turn thermostat (potentiometer) dial until a call for heat is made.
  - 1) Temperature light comes on.
  - 2) L1 voltage is supplied to the other side of contactor coils. Coils are energized and contacts close.
- 3) Heating elements are then energized and the cooking surface begins to heat up.
4. Control thermostat reaches set point temperature and contacts (N.O.) open.
  - A. Temperature light goes out.
  - B. L1 voltage is removed from one side of contactor coils. Coils are de-energized and contacts open.
  - C. Heating elements are then de-energized allowing the cooking surface to cool.
5. Control thermostat temperature drops below set point and contacts (N.O.) close.
  - A. Cooking surface temperature is maintained by the heaters cycling with the control thermostat until the thermostat dial is turned to the OFF position or the power switch is turned OFF.



**Gas Model**

1. Conditions.
  - A. Unit connected to correct voltage, polarity is correct and is properly grounded.
  - B. Power switch OFF.
  - C. Gas supply valve is ON.
  - D. Limit switch closed (pan down).
  - E. Thermostat (potentiometer) dial OFF ( 0 ohms between wiper arm terminal (red lead) & one side of the coil (white lead) CW rotation).
  - F. Temperature controller internal relay contacts (N.O.) are open.
  - G. Temperature light off.
  - H. Ignition light off.
  - I. High limit thermostat contacts (N.C.) closed.
2. Power switch ON.
  - A. Temperature controller receives power from L1 (120VAC) and NEUTRAL and is energized through L1 & L2 terminals on controller.
  - B. L1 (120VAC) to the common side of internal relay contacts.
  - C. NEUTRAL to one side of the temperature light and step down transformer (120VAC to 24VAC).
3. Turn thermostat (potentiometer) dial until a call for heat is made.
  - A. Internal relay on temperature controller is energized and the (N.O.) contacts close.
  - B. Power from L1 (120VAC) is then supplied to the other side of the temperature light and the step down transformer (120VAC to 24VAC).
    - 1) Temperature light comes on and the step down transformer is energized.
4. Ignition module is energized (24VAC) through the high limit (N.C.) contacts and ground.
  - A. Ignition trial cycle begins.
    - 1) Module delays energizing HSI for a 5 second purge time to allow any residual gas to dissipate. After purge time elapses, HSI begins a 3 second heat up time.
    - 2) After HSI heat up time elapses, the gas solenoid valve opens to supply gas to the hot ignitor and the ignition light comes on.
- 3) When burner lights, flame sense probe detects flame, HSI de-energizes after an 8.5 second ignition trial time, gas solenoid valve stays open and heating begins.
- 4) If burner flame is not detected after ignition trial time elapses, then the ignition control module locks out power to the gas solenoid valve. The module remains locked out until the thermostat (potentiometer) dial is turned to OFF then back to a set point temperature or the power switch is turned OFF then back ON again.
5. Temperature controller reaches set point temperature.
  - A. Internal relay on temperature controller is de-energized and the contacts open.
  - B. Temperature light goes out.
  - C. Power is removed from the ignition control module.
    - 1) Gas solenoid valve closes.
    - 2) Burner shuts off.
    - 3) Ignition light goes out.
6. Temperature controller drops below set point.
  - A. Cooking surface temperature is maintained by the gas burner cycling with the temperature controller until the potentiometer dial is turned to the OFF position or the power switch is turned OFF.

**SCHEMATIC DIAGRAMS**

**Electric Model**

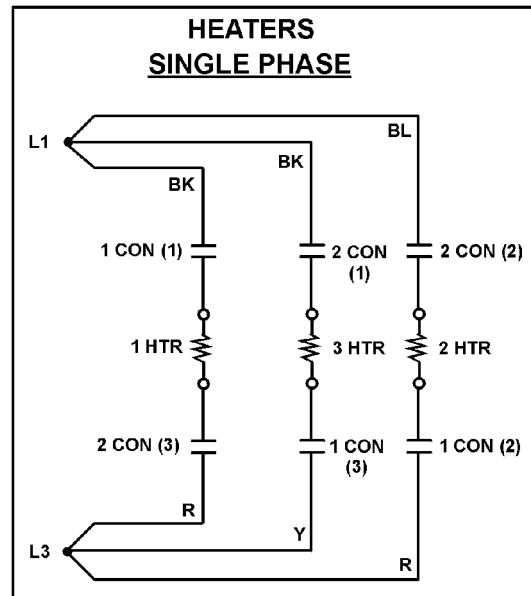
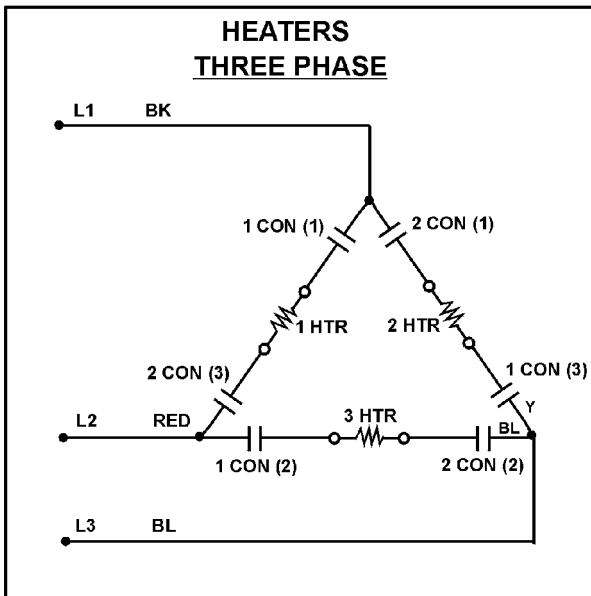
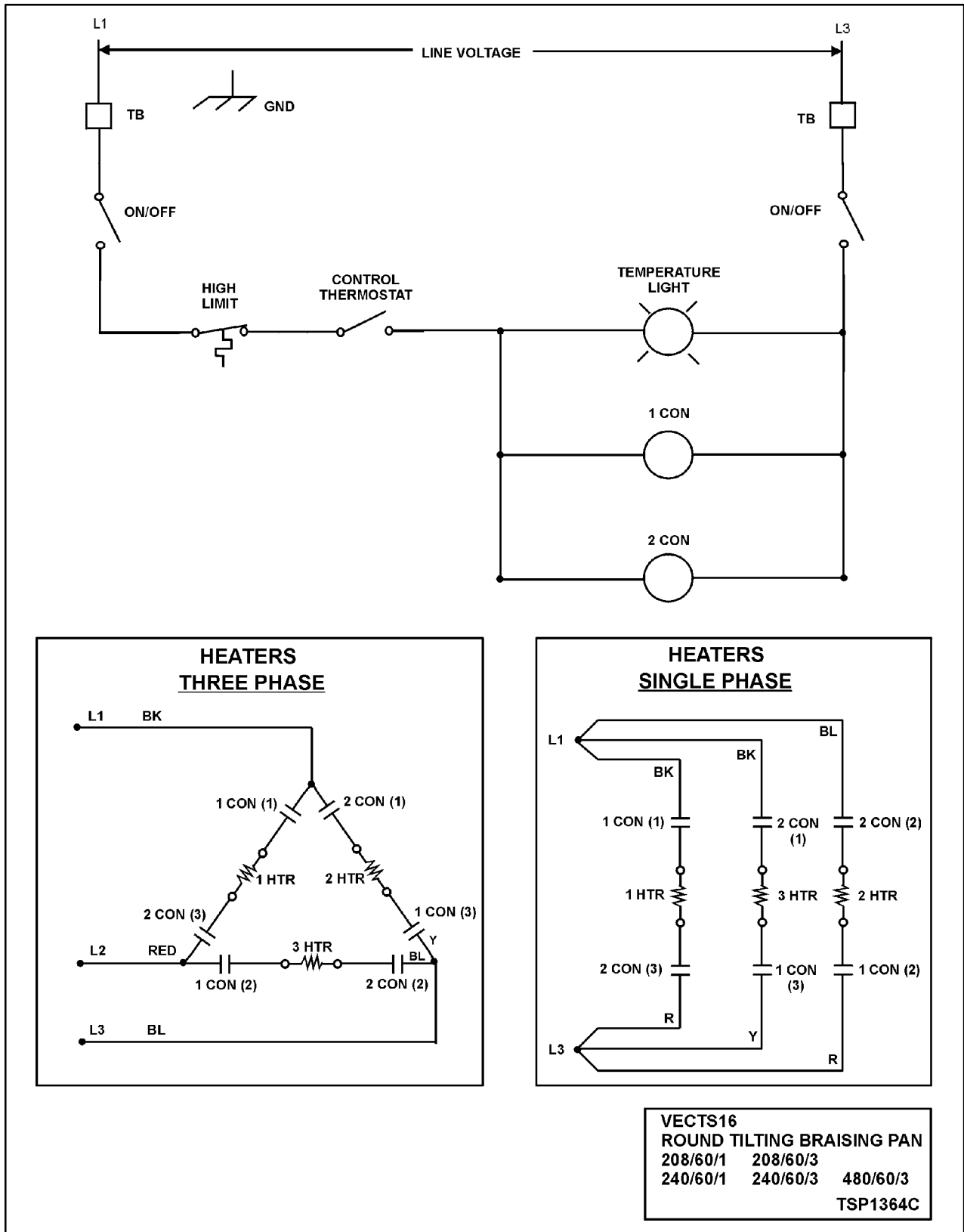

**VECTS16**  
**ROUND TILTING BRAISING PAN**  
 208/60/1 208/60/3  
 240/60/1 240/60/3 480/60/3  
**TSP1364C**

Gas Model

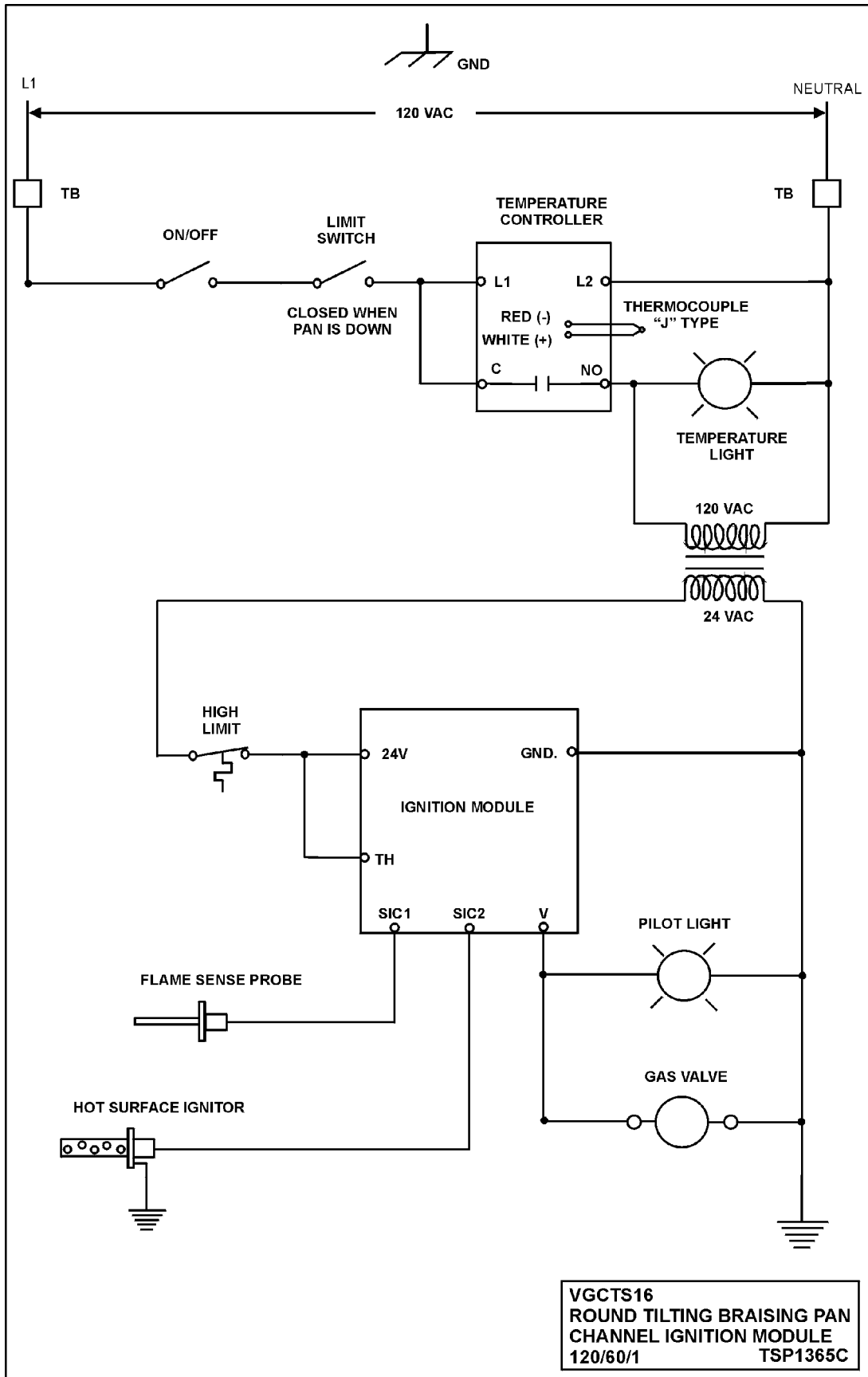

WIRING DIAGRAMS

Electric Model (208/240V)

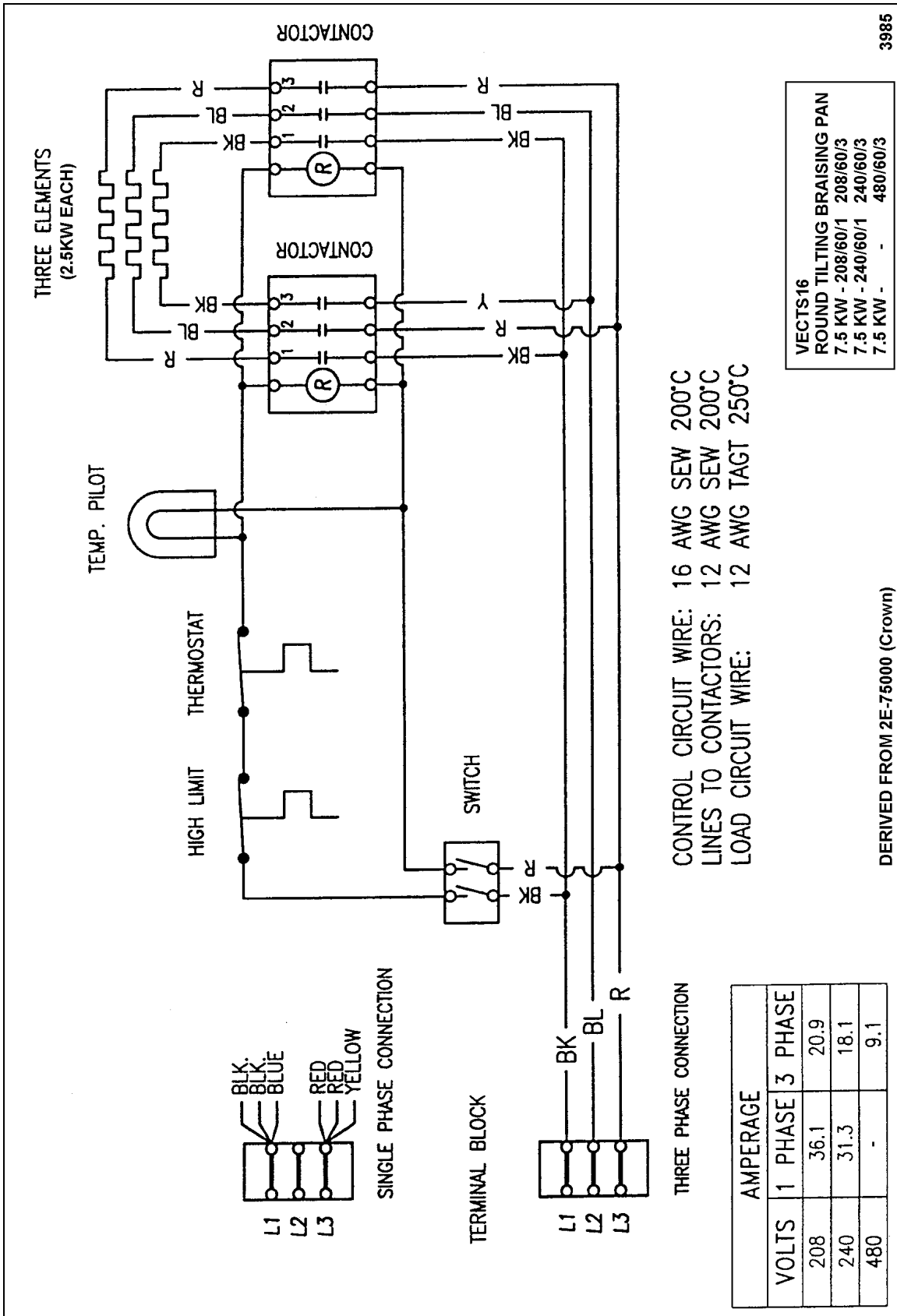

Electric Model (480V)

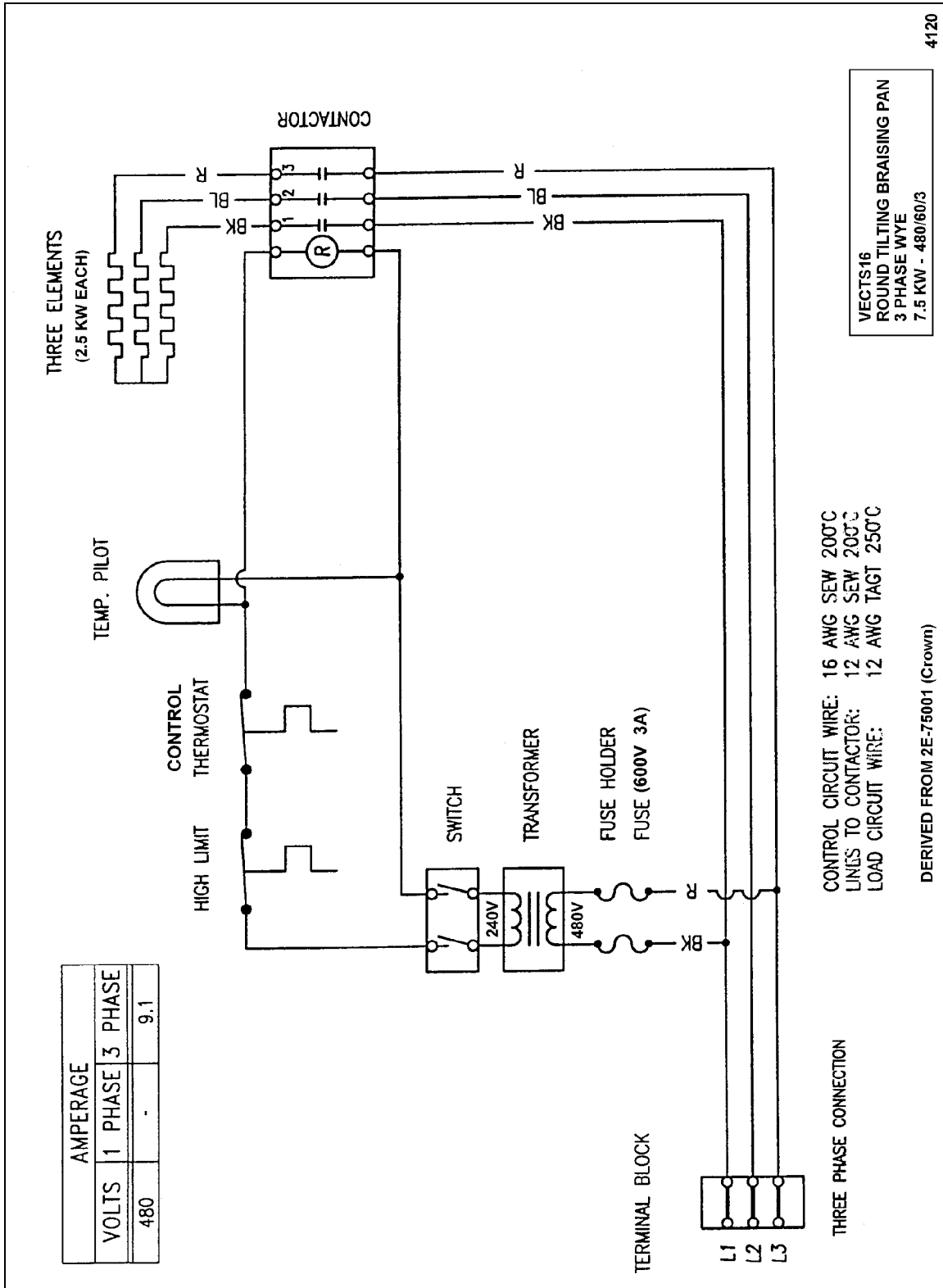

Gas Model

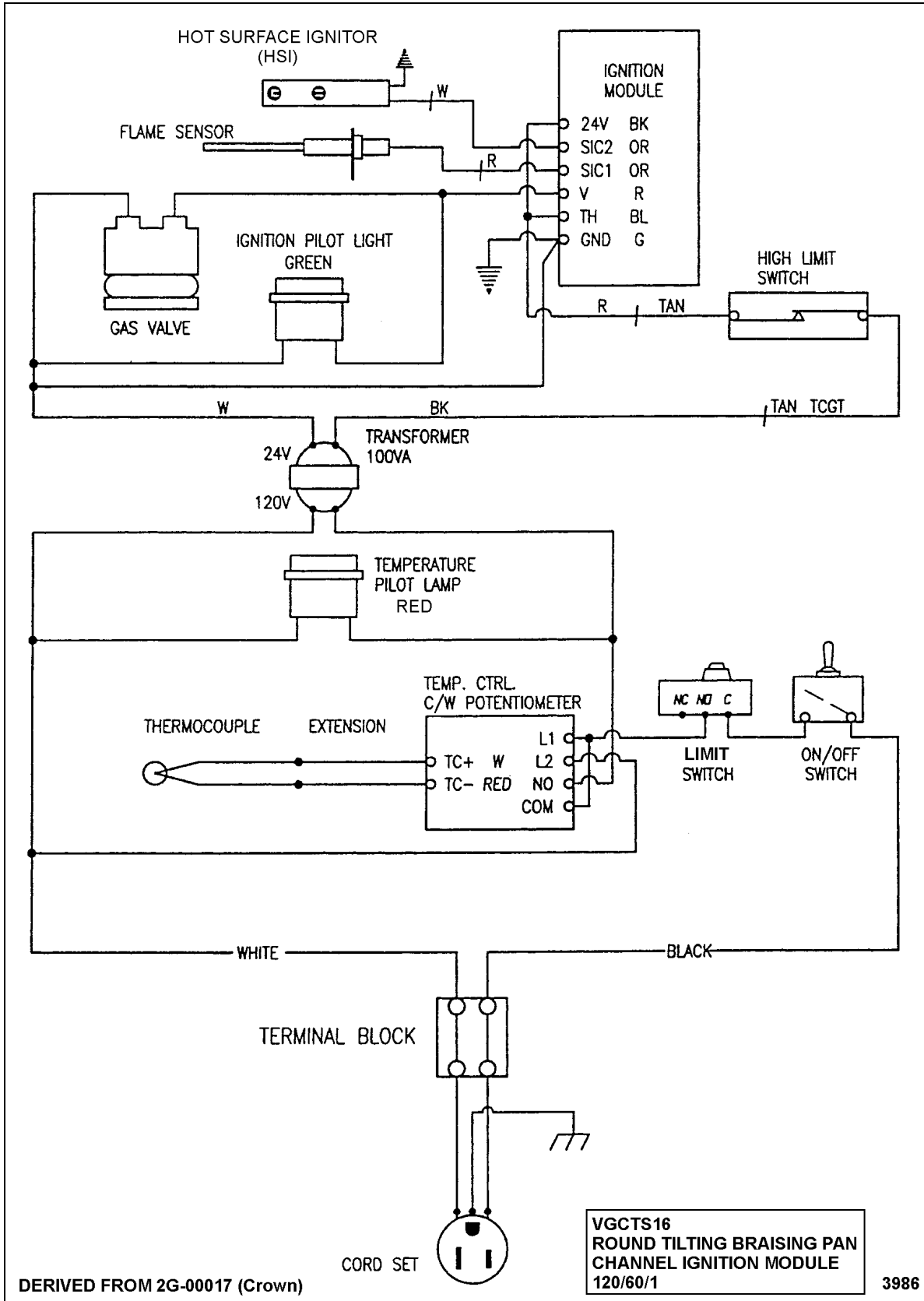

# TROUBLESHOOTING

## ALL MODELS

**WARNING:** CERTAIN PROCEDURES IN THIS SECTION REQUIRE ELECTRICAL TESTS OR MEASUREMENTS WHILE POWER IS APPLIED TO THE MACHINE. EXERCISE EXTREME CAUTION AT ALL TIMES. IF TEST POINTS ARE NOT EASILY ACCESSIBLE, DISCONNECT POWER, ATTACH TEST EQUIPMENT AND REAPPLY POWER TO TEST.

SYMPTOM	POSSIBLE CAUSES
Unit will not heat (temperature light off).	<ol style="list-style-type: none"> <li>1. Check incoming voltage.</li> <li>2. Control thermostat not turned on or remains open.</li> <li>3. Power switch malfunction.</li> <li>4. High limit thermostat open.</li> <li>5. Heating element inoperative (electric model).</li> <li>6. Heater contactor(s) malfunction (electric model).</li> </ol>
Pan difficult to tilt.	<ol style="list-style-type: none"> <li>1. Dirt in oilite bearings causing it to bind. See "BEARINGS UNDER REMOVAL AND REPLACEMENT OF PARTS".</li> </ol> <p><b>NOTE:</b> Never grease or oil the pivot bearings as this may cause problems with tilting. Bearings are oilite and never require lubrication.</p>
Cooking temperature incorrect.	<ol style="list-style-type: none"> <li>1. Thermocouple not secured properly to bottom of pan.</li> <li>2. Thermocouple lead wire(s) pulled loose from connection or damaged.</li> </ol>

**GAS MODELS ONLY**

SYMPTOM	POSSIBLE CAUSES
Burner won't light.	<ol style="list-style-type: none"> <li>1. Gas not on.</li> <li>2. Pan not down to close limit switch.</li> <li>3. Unit not properly grounded and/or polarity of incoming power is incorrect.</li> <li>4. Low incoming gas pressure.</li> <li>5. Gas solenoid valve malfunction.</li> <li>6. HSI not operating. See "HOT SURFACE IGNITOR (GAS MODEL)" in "SERVICE PROCEDURES AND ADJUSTMENTS".</li> <li>7. Ignition module not receiving power.                             <ol style="list-style-type: none"> <li>A. Check transformer for 24VAC output to module.</li> <li>B. High limit thermostat remains open.</li> <li>C. Temperature controller or potentiometer malfunction. See "TEMPERATURE CONTROLLER AND POTENTIOMETER (GAS MODEL)" in "SERVICE PROCEDURES AND ADJUSTMENTS".</li> </ol> </li> <li>8. Ignition module malfunction.</li> </ol>
Burner won't stay lit.	<ol style="list-style-type: none"> <li>1. Gas pressure low. See "MANIFOLD PRESSURE ADJUSTMENT (GAS)" in "SERVICE PROCEDURES AND ADJUSTMENTS".</li> <li>2. Check position of flame sense probe. See "FLAME SENSE PROBE (GAS MODELS)" in SERVICE PROCEDURES AND ADJUSTMENTS".</li> <li>3. Flame sense probe malfunction.</li> <li>4. Ignition module malfunction.</li> <li>5. Check gas orifice for obstruction.</li> </ol>
HSI heats up but burner will not light.	<ol style="list-style-type: none"> <li>1. Gas supply is off.</li> <li>2. Gas solenoid valve malfunction.</li> <li>3. Ignition module malfunction.</li> </ol>